

9 Watts

- Ultra Compact SIP8 Package
- Smallest Footprint 9W Converter
- Single & Dual Outputs
- 2:1 Input Range
- Operating Temperature -40°C to +85°C
- 1.6kVDC Input to Output Isolation
- Fully Regulated Output
- No Minimum Load Required
- Remote On/Off
- 3 Year Warranty



Dimensions:

ICZ:
0.86 x 0.38 x 0.44" (21.8 x 9.6 x 11.2 mm)

Models & Ratings

Input Voltage	Output Voltage	Output Current	Input Current ⁽¹⁾		Maximum Capacitive Load ⁽²⁾	Efficiency	Model Number
			No Load	Full Load			
12V (9-18 V)	3.3 V	2000 mA	15 mA	679 mA	2600 µF	81%	ICZ0912S3V3
	5.0 V	1600 mA	15 mA	784 mA	1300 µF	85%	ICZ0912S05
	9.0 V	1000 mA	15 mA	862 mA	800 µF	87%	ICZ0912S09
	12.0 V	750 mA	15 mA	852 mA	560 µF	88%	ICZ0912S12
	15.0 V	600 mA	15 mA	843 mA	470 µF	89%	ICZ0912S15
	24.0 V	375 mA	15 mA	843 mA	200 µF	89%	ICZ0912S24
	±5.0 V	±800 mA	15 mA	784 mA	±800 µF	85%	ICZ0912D05
	±12.0 V	±375 mA	15 mA	852 mA	±390 µF	88%	ICZ0912D12
24V (18-36 V)	3.3 V	2000 mA	15 mA	344 mA	2600 µF	80%	ICZ0924S3V3
	5.0 V	1600 mA	15 mA	392 mA	1300 µF	85%	ICZ0924S05
	9.0 V	1000 mA	15 mA	426 mA	800 µF	88%	ICZ0924S09
	12.0 V	750 mA	15 mA	421 mA	560 µF	89%	ICZ0924S12
	15.0 V	600 mA	15 mA	417 mA	470 µF	90%	ICZ0924S15
	24.0 V	375 mA	15 mA	417 mA	200 µF	90%	ICZ0924S24
	±5.0 V	±800 mA	15 mA	388 mA	±800 µF	86%	ICZ0924D05
	±12.0 V	±375 mA	15 mA	421 mA	±390 µF	89%	ICZ0924D12
48V (36-75 V)	3.3 V	2000 mA	10 mA	168 mA	2600 µF	82%	ICZ0948S3V3
	5.0 V	1600 mA	10 mA	196 mA	1300 µF	85%	ICZ0948S05
	9.0 V	1000 mA	10 mA	213 mA	800 µF	88%	ICZ0948S09
	12.0 V	750 mA	10 mA	211 mA	560 µF	89%	ICZ0948S12
	15.0 V	600 mA	10 mA	211 mA	470 µF	89%	ICZ0948S15
	24.0 V	375 mA	10 mA	211 mA	200 µF	89%	ICZ0948S24
	±5.0 V	±800 mA	10 mA	194 mA	±800 µF	86%	ICZ0948D05
	±12.0 V	±375 mA	10 mA	216 mA	±390 µF	87%	ICZ0948D12
	±15.0 V	±300 mA	10 mA	216 mA	±200 µF	87%	ICZ0948D15

Notes

1. Input currents measured at nominal input voltage.
2. Maximum capacitive load is per output.

3. Standard tube quantity = 20

Input

Characteristic	Minimum	Typical	Maximum	Units	Notes & Conditions
Input Voltage Range	9		18	VDC	12 V nominal
	18		36	VDC	24 V nominal
	36		75	VDC	48 V nominal
Input Filter	Capacitor				
Input Reflected Ripple			30	mA pk-pk	Through 12 μ H inductor and 47 μ F capacitor
Input Surge			25	VDC for 100 ms	12 V models
			50	VDC for 100 ms	24 V models
			100	VDC for 100 ms	48 V models
Undervoltage Lockout	On at >8.9V, Off at <7.1V				12 V models
	On at >16V, Off at <13.1V				24 V models
	On at >33V, Off at <30.1V				48 V models

Output

Characteristic	Minimum	Typical	Maximum	Units	Notes & Conditions
Output Voltage	3.3		30	VDC	See Models and Ratings table
Initial Set Accuracy			± 1	%	At full load
Minimum Load	0			A	No minimum load required
Line Regulation			± 0.2	%	
Load Regulation			± 0.5	%	Single output from 0 to full load
			± 1	%	3V3 and dual output from 0 to full load
Cross Regulation			± 5	%	On dual output models when one load is varied between 25% and 100% and other is fixed at 100%
Transient Response			$\pm 5/\pm 3$	% deviation	For 3V3 output models / all other models. Recovery within 2% in less than 250 μ s for a 25% load change
Ripple & Noise			75	mV pk-pk	3.3-9V/12-24V. 20 MHz bandwidth. Measured using 1 μ F ceramic and 10 μ F electrolytic capacitors
Overload Protection		150		%	
Short Circuit Protection					Continuous, with auto recovery
Maximum Capacitive Load					See Models and Ratings table
Temperature Coefficient			0.02	%/°C	
Remote On/Off	Output is on if remote on/off (pin 3) is open circuit. Output is off if 2-4 mA current is applied to remote on/off (pin 3) via 1 k Ω resistor Maximum pin voltage is 5V and maximum current into pin 3 is 4 mA. Note: Output may be affected with current into the pin as low as 10 μ A.				

General

Characteristic	Minimum	Typical	Maximum	Units	Notes & Conditions
Efficiency		88		%	See Models and Ratings table
Isolation: Input to Output	1600			VDC	For 60s. Insulation: Functional
Isolation: Input to Case	1000				For 60s. Insulation: Functional
Continuous Working Voltage: Input to Output			500	VDC	200V r.m.s.
Switching Frequency		400/500		kHz	12 and 24 Vin/48 Vin
Isolation Resistance	10^9			Ω	
Isolation Capacitance		50		pF	
Power Density			65	W/in ³	
Mean Time Between Failure	900			khrs	MIL-HDBK-217F, +25 °C GB
Case Material					Copper
Potting Material					Epoxy UL94V-0 rated
Pin Material					Solder coated phosphor bronze C519R-H
Solder Profile					260 °C max, 1.5mm from case 10s max
Weight		0.016 (7.3)		lb (g)	

Environmental

Characteristic	Minimum	Typical	Maximum	Units	Notes & Conditions
Operating Temperature	-40		+85	°C	Derate from 100% load at +60 °C to no load at +85 °C. Derate from 100% load at +50 °C to no load at +85 °C for 3V3 output models.
Storage Temperature	-55		+125	°C	
Case Temperature			+100	°C	
Humidity			95	%RH	Non-condensing
Cooling					Natural convection

Derating Curve

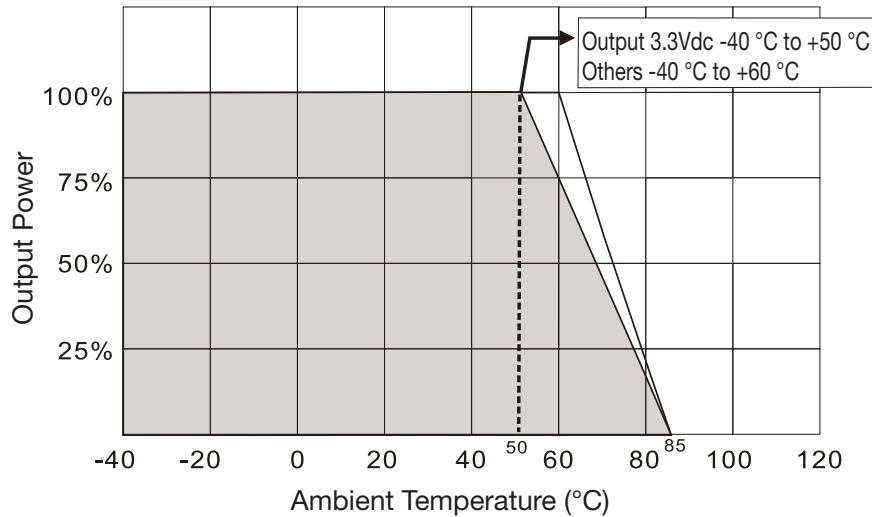

EMC: Emissions

Phenomenon	Standard	Test Level	Notes & Conditions
Conducted	EN55032	Class A	See application note
Radiated	EN55032	Class A	See application note

EMC: Immunity

Phenomenon	Standard	Test Level	Criteria	Notes & Conditions
ESD Immunity	EN61000-4-2	±6 kV/±8 kV	A	Contact/Air Discharge
Radiated Immunity	EN61000-4-3	20 Vrms	A	
EFT/Burst	EN61000-4-4	±2 kV	A	See application note
Surges	EN61000-4-5	±2 kV	A	See application note
Conducted Immunity	EN61000-4-6	10 V rms	A	
Magnetic Fields	EN61000-4-8	100 A/m	A	

Safety

Agency	Standard	Notes & Conditions
UL	UL/cUL 60950-1, 62368-1	ITE

Mechanical Details

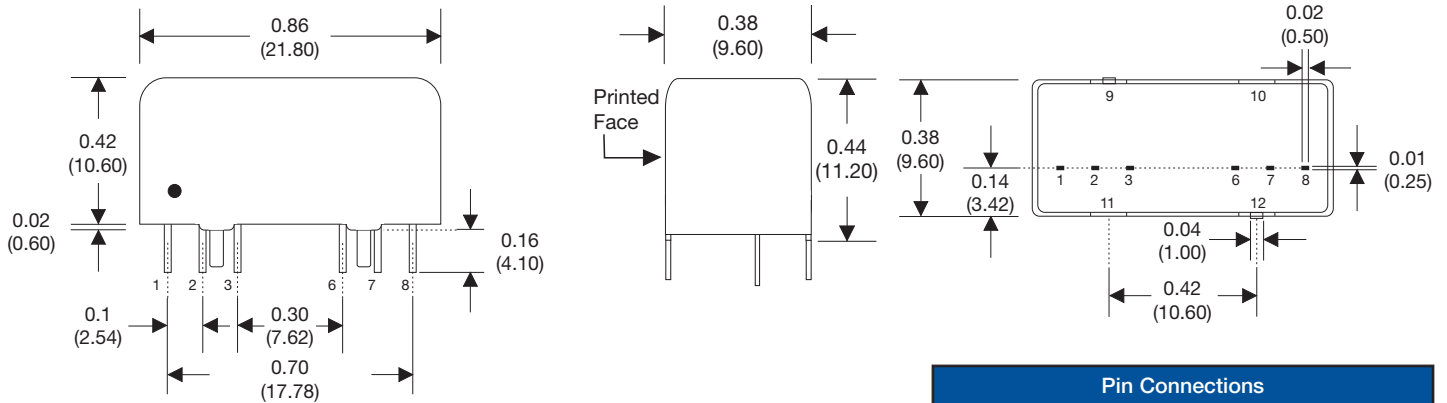

Notes

- All dimensions are in inches (mm)
- Weight: 0.016 lbs (7.3 g) approx.
- Pin diameter: 0.02±0.002 (0.5±0.05)
- Pin pitch tolerance: ±0.014 (±0.35)
- Case tolerance: ±0.02 (±0.5)

Pin Connections

Pin	Single	Dual
1	-Vin	-Vin
2	+Vin	+Vin
3	Remote On/Off	Remote On/Off
6	+Vout	+Vout
7	-Vout	Common
8	No Connection	-Vout
9	Case	Case
10	Stand Off	Stand Off
11	Stand Off	Stand Off
12	Case	Case

Application Notes

EMI Filter

Single Output Models

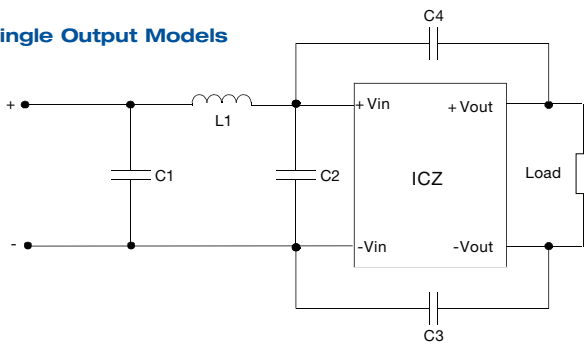

Dual Output Models

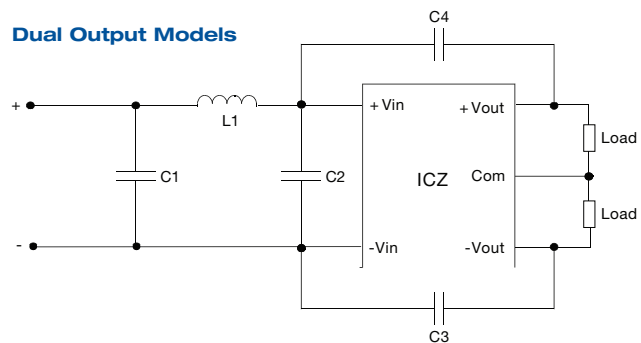

Models	C1	C2	C3, C4	L1
12 Vin	1210, 10µF/35V		1808, 1000 pF/ 3kV	3.3µH
24 Vin & 48 Vin	1210, 4.7µF /100 V	1210, 4.7µF/100 V	1808, 1000 pF/ 3kV	10µH

EFT/Surge Filter

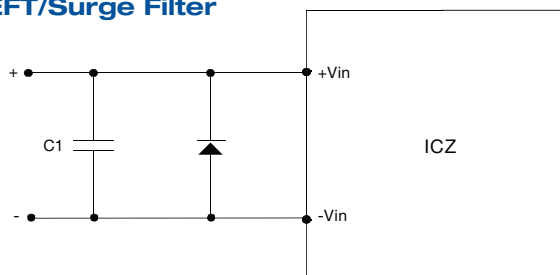

Models	C1	D1
12 Vin	330 µF, 100 V	TVS, 3 kW, 26 V
24 Vin	330 µF, 100 V	TVS, 3 kW, 70 V
48 Vin	330 µF, 100 V	TVS, 3 kW, 120 V

C1 suggested series Nippon Chemicon KY